

AVIATION

C-130

INSTRUCTION MANUAL

For intermediate to advanced pilots



SAFETY INSTRUCTIONS

1. Please read this manual carefully and follow the instructions before you use this product.
2. This airplane is not a toy, due to its advanced flying qualities it is only suitable for experienced pilots. If you are a novice then please only operate with the assistance of an experienced pilot.
3. Not recommended for children under 14 years old.
4. Please set up this plane according to the instructions and make sure you keep your hands and other parts of your body out of the way of the rotating propellers at all times. Failure to do so will result in damage to yourself and to the airplane.
5. Do not fly in thunderstorms, strong winds or wet weather.
6. Never fly R/C planes where there are overhead power lines, automobiles, airports, railway lines or near a highway.
7. Never fly R/C planes where there are crowds of people or over organised games. This airplane requires a very flat landing and take-off area that is clear of trees and other obstacles.
Remember safety is the responsibility of the pilot.
8. Do not attempt to catch the plane when you are flying it.
9. The operator will bear the full responsibility of flying and the proper operation and usage of this model. We at Hobbyking will not be responsible for any liability or loss due to improper use of this model.

The C-130 is an American four-engine turboprop military transport aircraft which is capable of using unprepared runways for takeoffs and landings. The C-130 was originally designed as a troop, medevac, and cargo transport aircraft. The versatile airframe has found uses in a variety of other roles, including as a gunship (AC-130), for airborne assault, search and rescue, scientific research support, weather reconnaissance, aerial refueling, maritime patrol and aerial firefighting. It is now the main tactical airlifter for many military forces worldwide.

The Blue Angels use a United States Marine Corps C-130T nicknamed "Fat Albert", for their logistics, carrying spare parts, equipment and to carry support personnel between shows. "Fat Albert Airlines" flies with an all Marine crew of three officers and five enlisted personnel.

Specifications:

Wingspan	1600 mm	Servos	
Length	1195 mm	Propellers	14 x 9 g
Flying Weight	2400 g (inc battery)	Battery	4 off 6.5 x 5" 4 Blade 2200mah 4S (14.8V) recommended (not supplied)
Power	4 x 2627 1000KV Brushless Motors	Included	
Speed Control	4 x 18A Brushless ESC		Retractable landing gear, flaps and lighting system

C-130 features:

1. This beautiful model is an accurate 1 : 25 scale replica of the C-130.
2. Electronic retractable scale landing gear with pre-programmed sequencing gear doors which operate close to a full scale. It's all fully assembled and tested by skilfull factory technicians.
3. Scale like operating fowler flaps for short take off and landing.
4. Four powerful brushless motors provide tremendous power for sharp take off like the full scale.
5. The iconic 4 blade propellers (2 x CW 2 X CCW) which come with this kit are highly efficient, powerful and true to scale.
6. This C-130 cargo door which can be operated by an aux channel on your computer radio. Good for any candy drops events at the flying fields! A cabin light is also added and it can be switched on / off automatically when the door is opened and closed.
7. Equipped with super bright navigational lights and landing lights which can be seen even in bright daylight.
8. Wings have special connectors build-in for quick and easy setup at the flying fields.
9. Scale detailed accessory plastic parts such as windshield wipers, pitot tubes and dew point sensors are also included in this kit.

■ Assembly

1

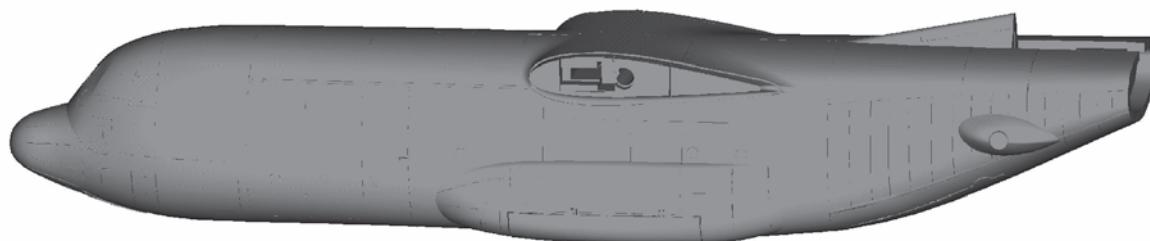

Main fuselage assembly.

2

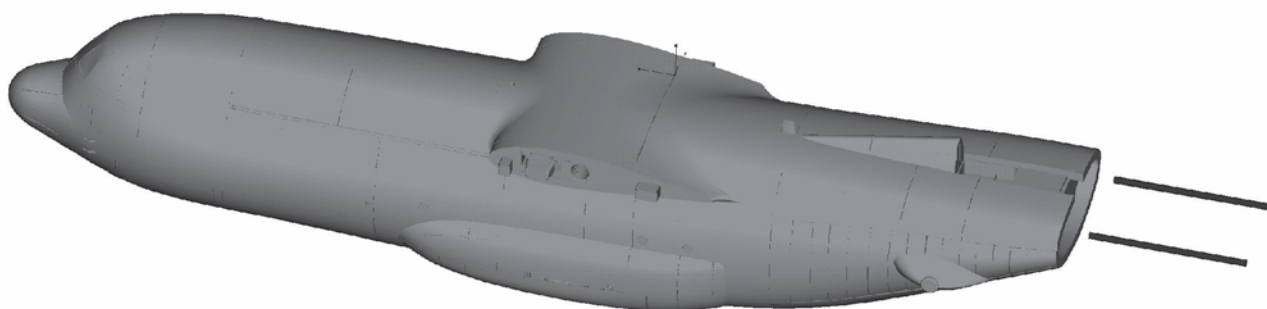

Install the fiberglass rods into the carbon sleeves at the rear of the fuselage as shown.

3

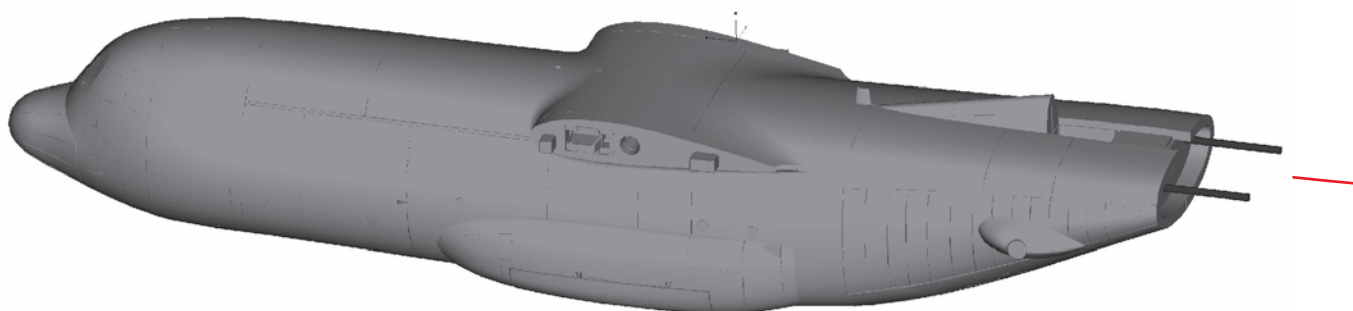

4

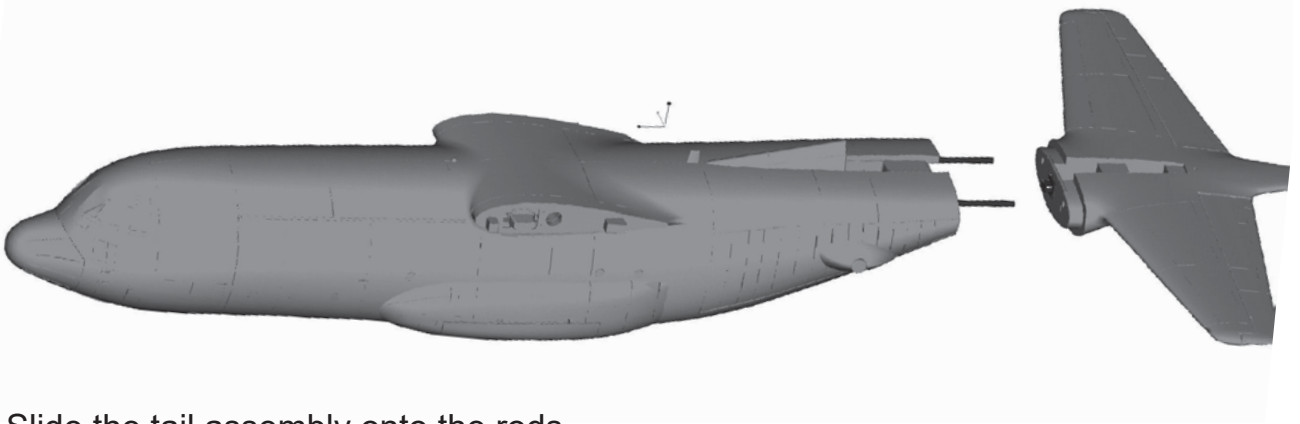

Slide the tail assembly onto the rods

5

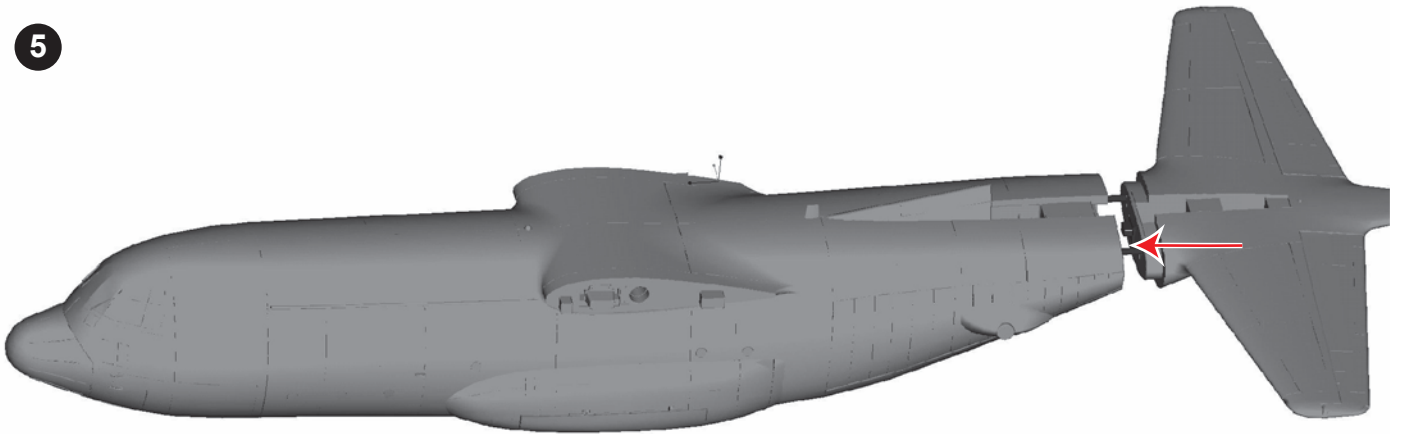

6

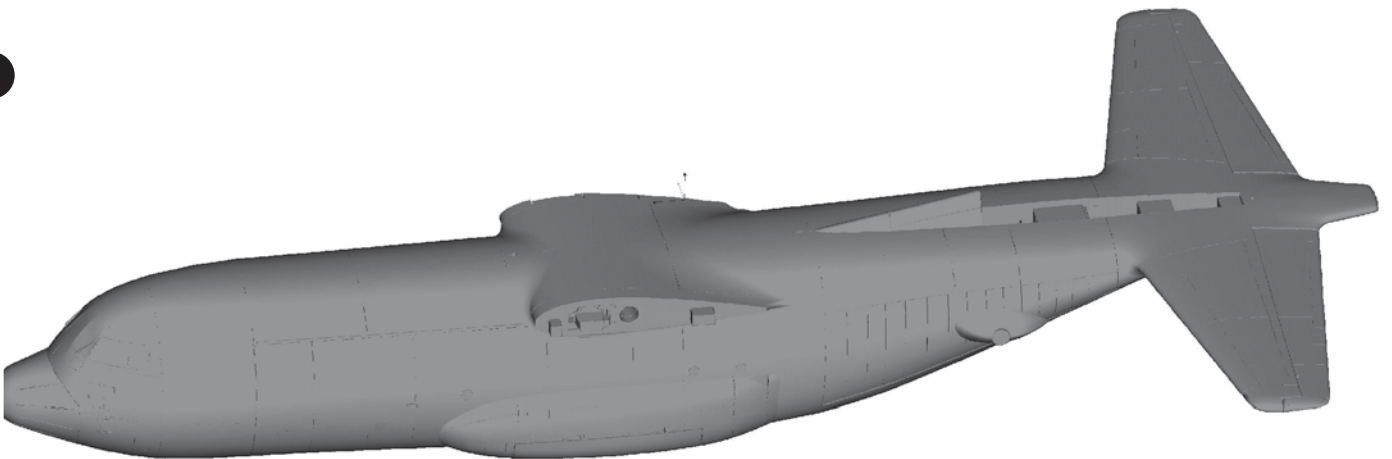

7

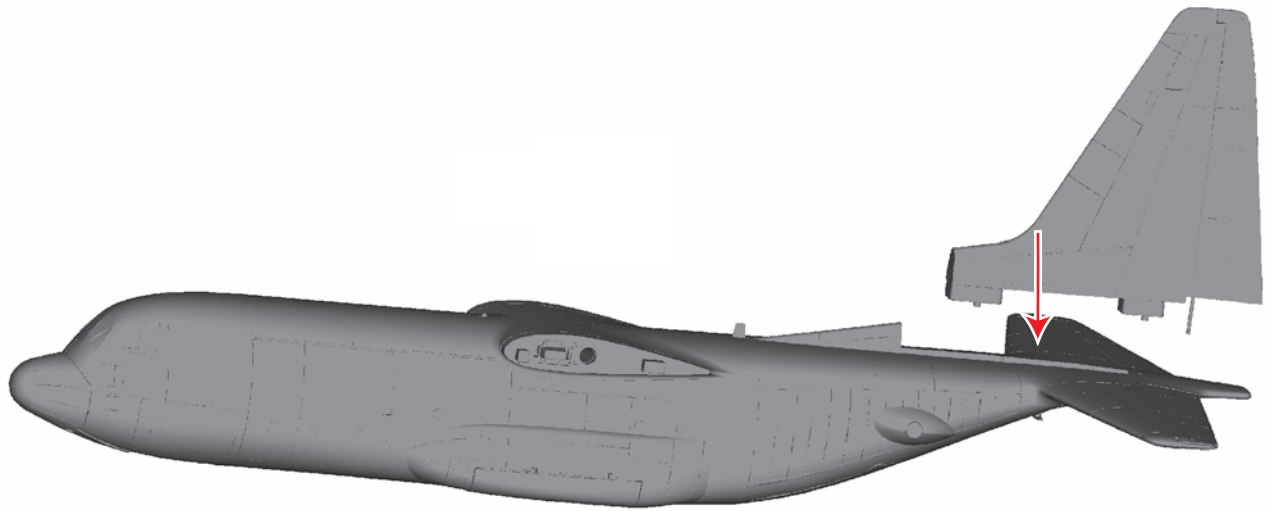

Then install the vertical fin onto the fuselage.

8

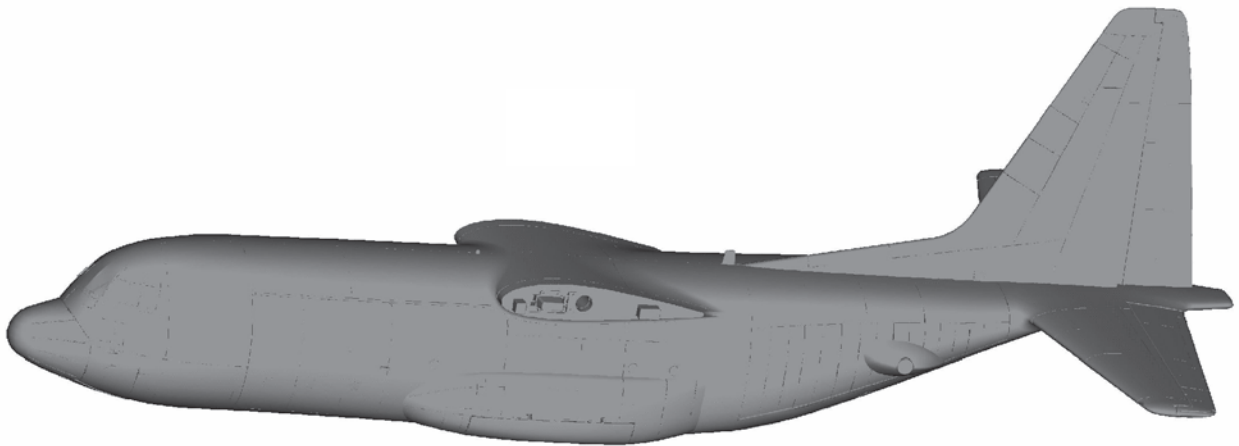

9

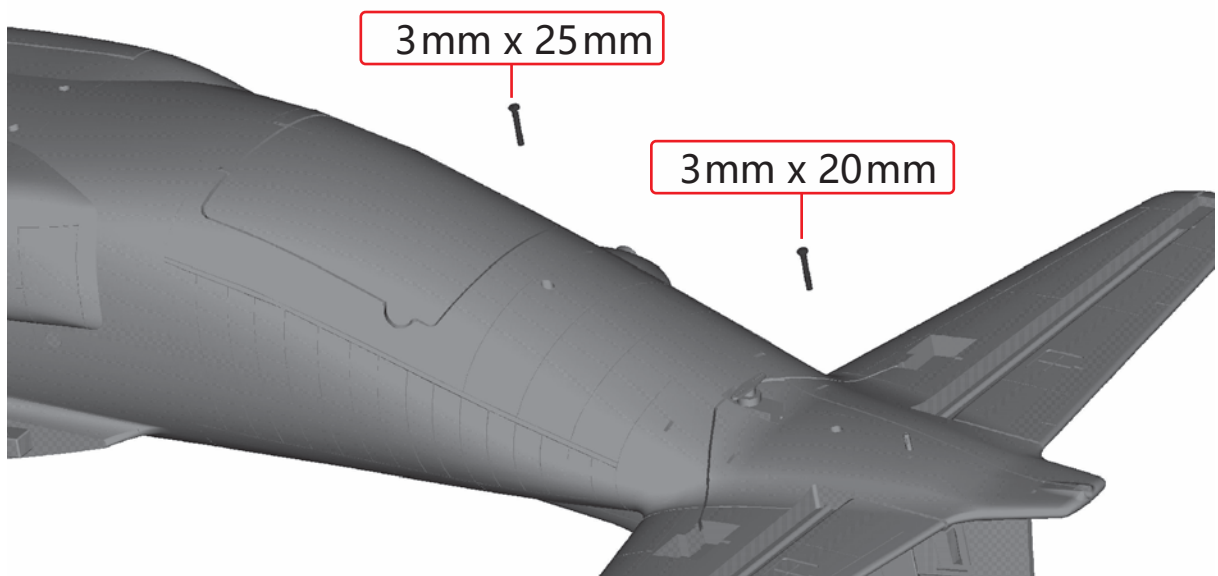

Use the supplied screws to lock the vertical fin onto the fuselage.

Note: The longer 3x25mm screw should be installed just behind the cargo bay door as shown in the picture above.

10

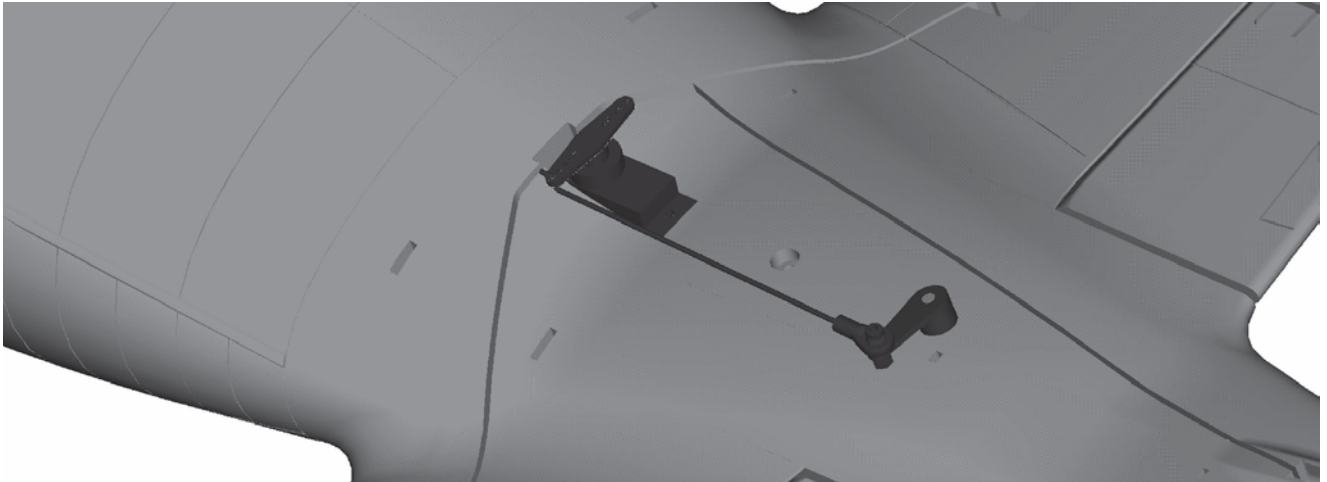

Install the supplied rudder steering control horn as shown in the picture.
(Z link goes to the servo horn).

11



Ensure the rudder control surface is aligned with the vertical fin.
Use an Allen key to tighten the grub screws of the control horn and also apply some Loctite glue onto the threads. The rudder servo horn and the rudder control horn should be at 90° to the main axis of the fuselage.

12



Slide into the fuselage the main wing spar.

13

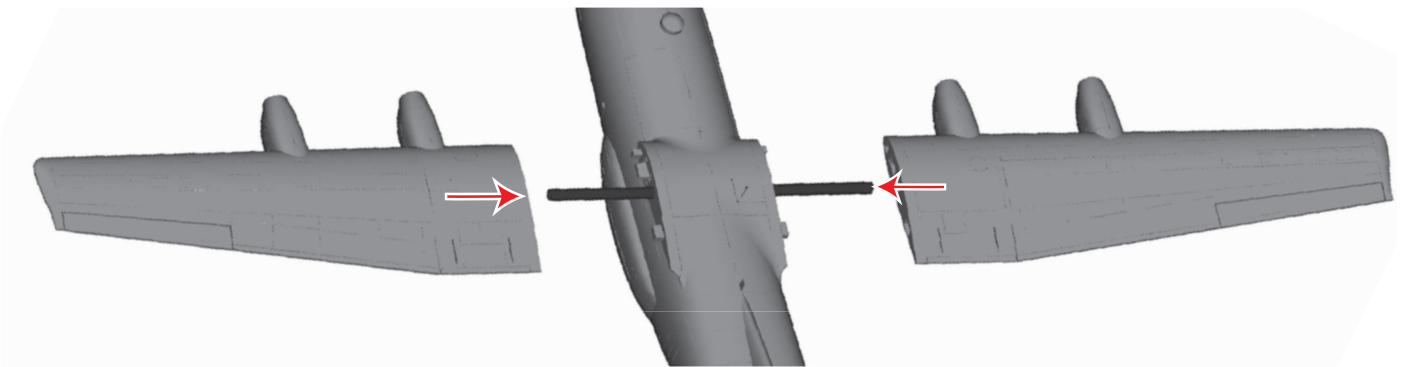

Install both wings.

14

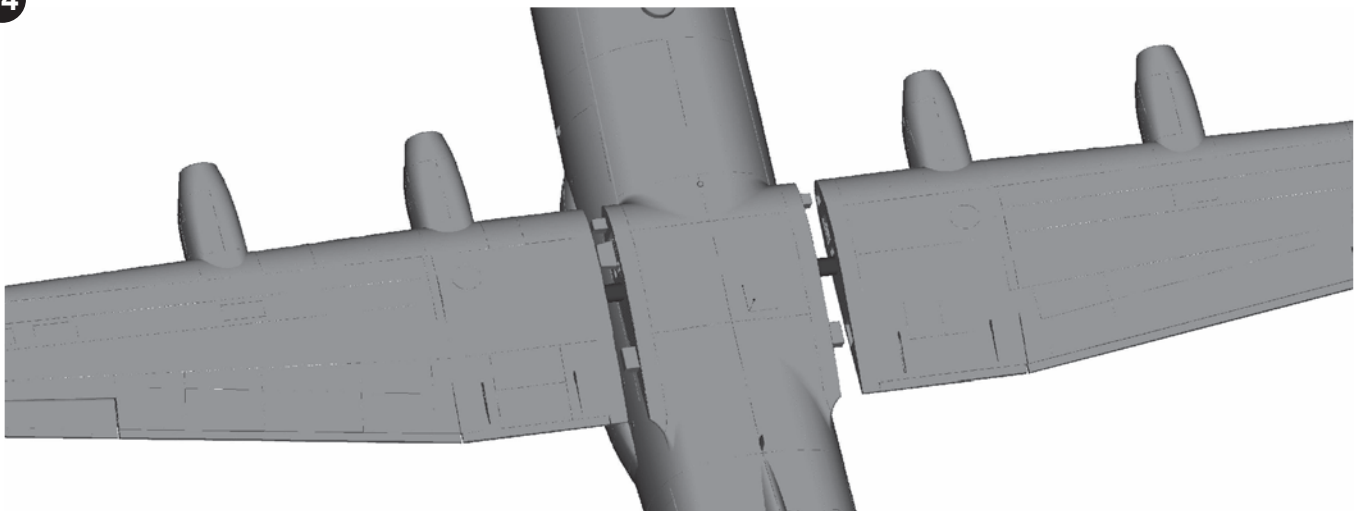

15

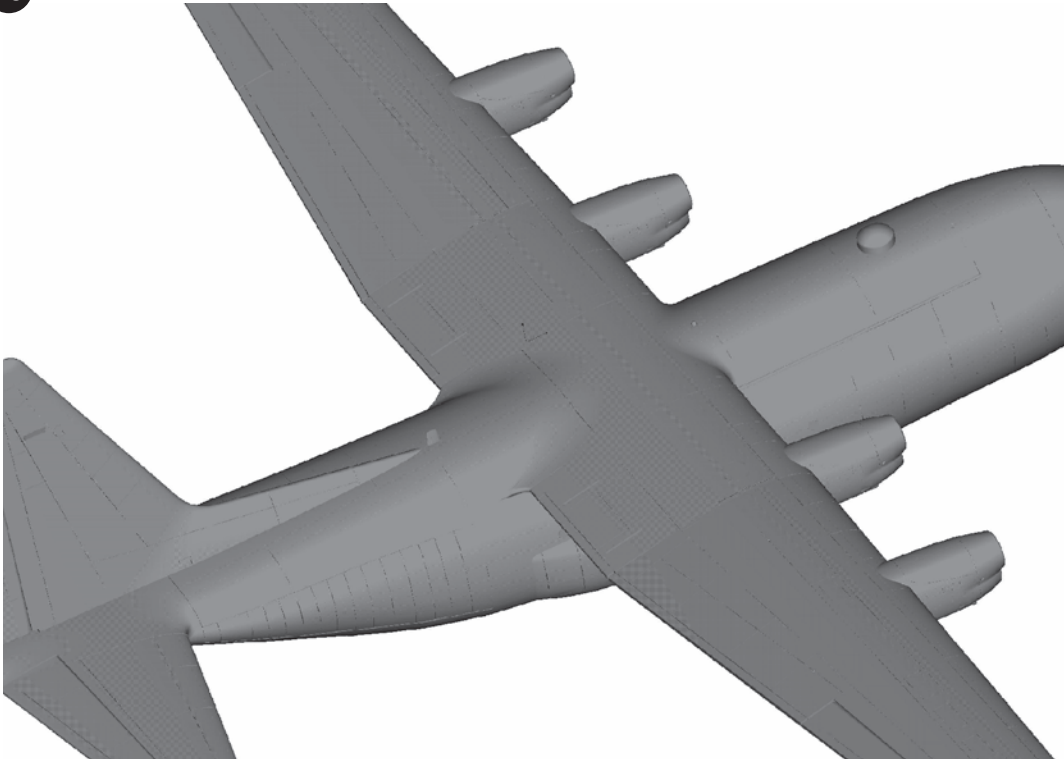

Push both wings up against the fuselage wing roots, make sure the electrical connectors on the wings line up and plug in correctly.

16

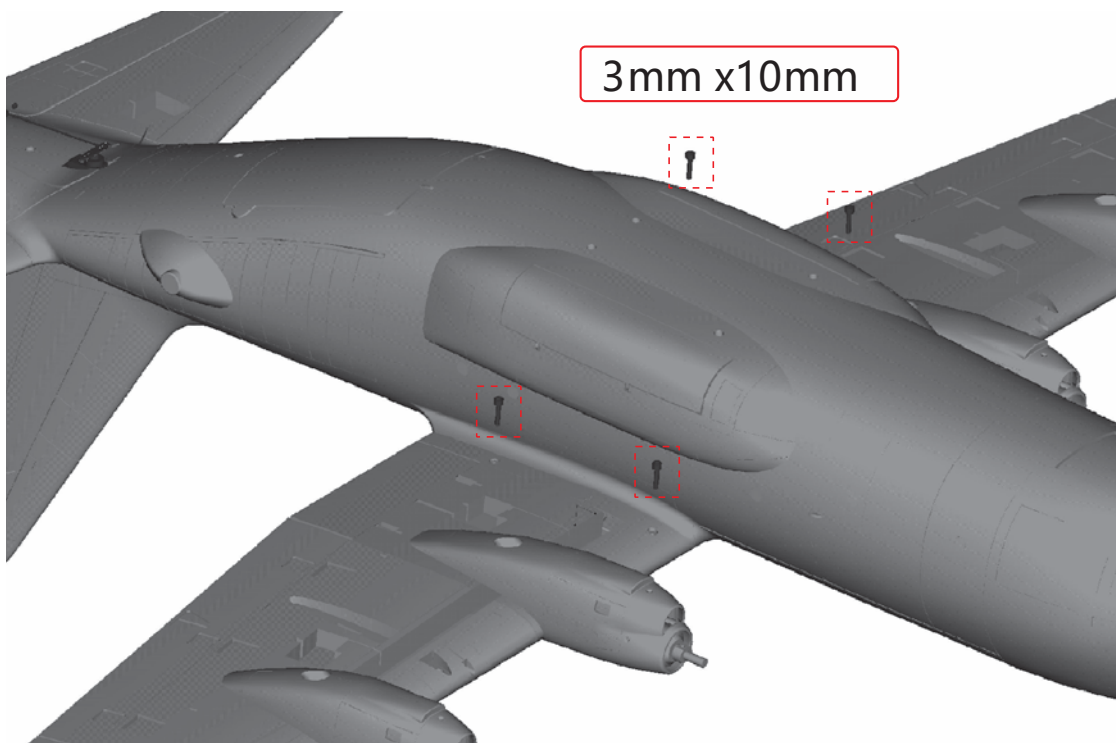

Insert 4 off 3mm x 10mm screws into the fuselage wing roots as shown. Use a Hex key with ball end to tighten the screws.

Note: Be careful not to make any dents on the fuselage when tightening the screws

17

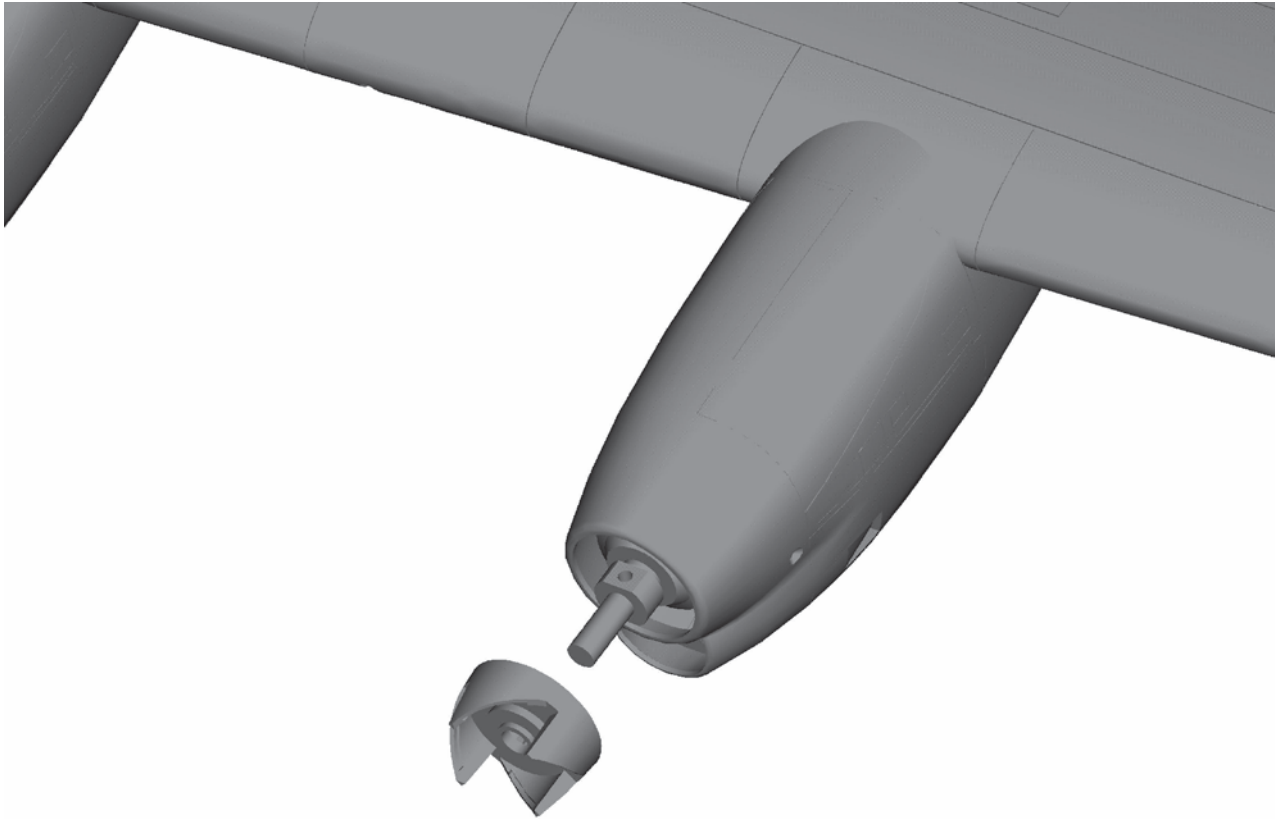

18

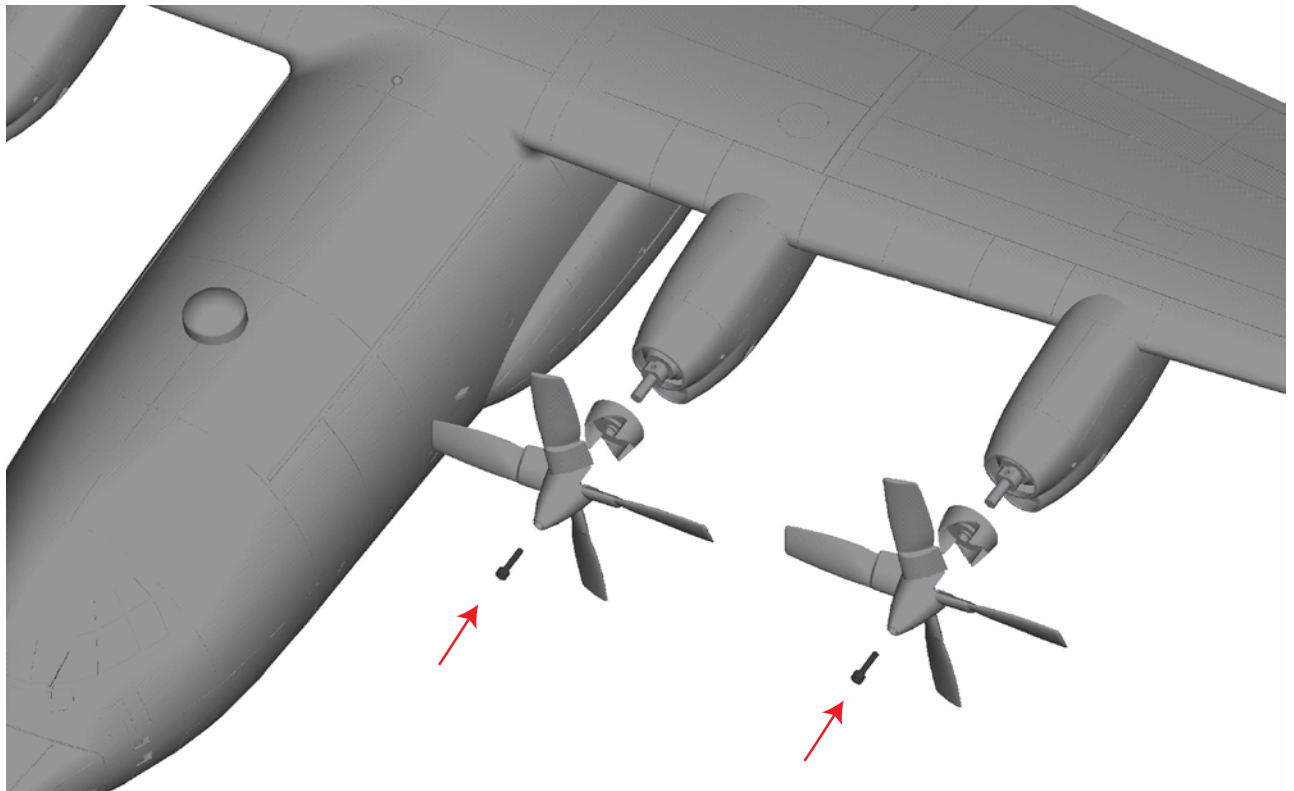

Install the propeller assemblies as shown. Use a Hex key to lock the prop adaptor onto the motor shaft then fit the propeller and spinner.

Note: Apply some Loctite to the threads and then tighten the screws securely.

19

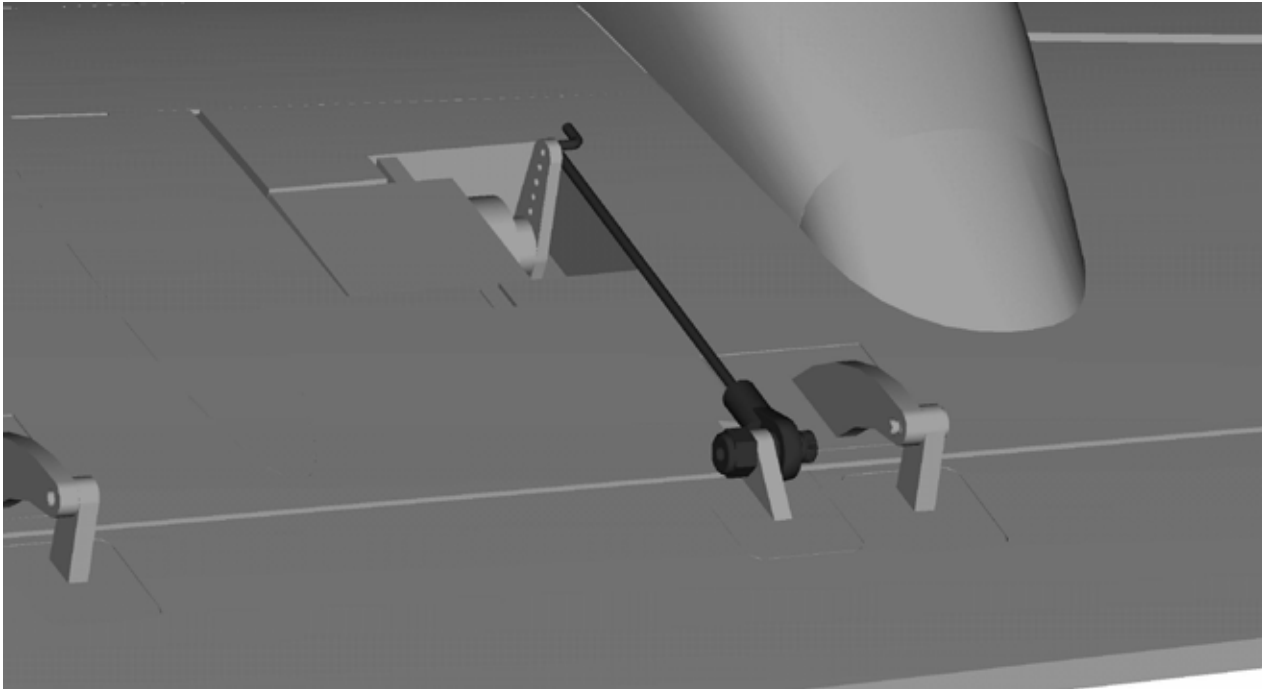

Install the outboard flap pushrod linkages to the flaps as shown.
(Z link to the servo horn).

20



Install the elevator pushrod linkage to the elevator as shown.
(Z link to the servo horn).



Figure 1

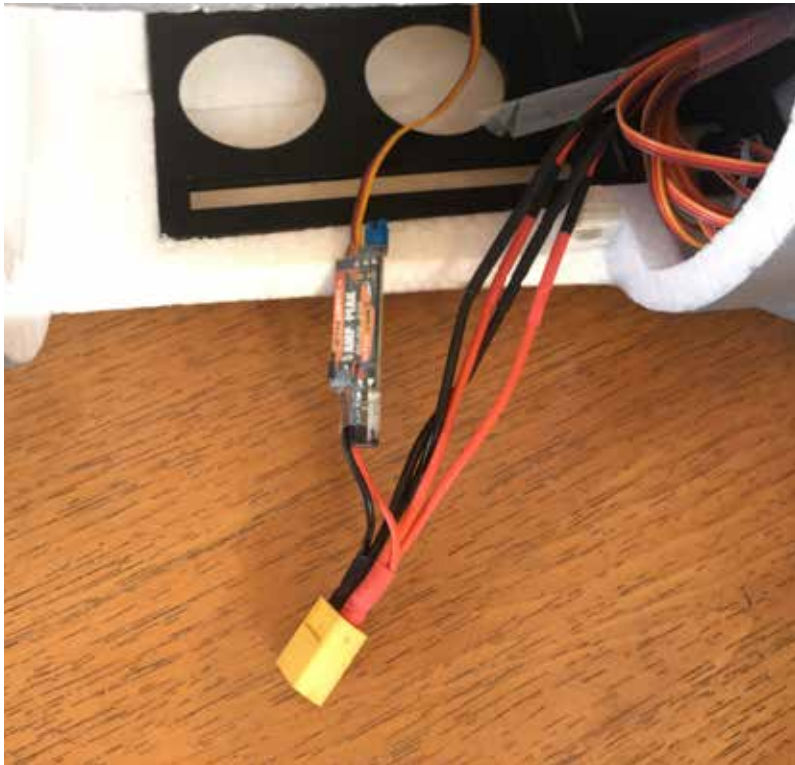

Figure 2

Plug in the UBEC cables to the power cables on the plane. Pay attention to the polarity and ensure that all the pins are fully seated into the socket. See pic #1 and #2.

■ Radio Control Setup

Please also study your computer radio instruction manual carefully for the programming and the proper setup of each function on this airplane.

Flaps setting procedure:

Note: Please do not have the flap control linkages attached until you have the radio set up done. Once you have set up your radio you may install the control linkages and fine tune the flap control surface travels evenly on both sets of flaps on both wings.

1. Switch on your radio, press menu and go to the Aircraft Type, choose a type with 2 aileron and 2 flap setup. After that, assign a two way switch for the flap channel and an aux channel with which to operate the outboard flaps and inboard flaps.
2. Flap (outboard flap} Flap 2 (inboard flap)
3. Plug the Flap servo leads into the designated channel outputs of your receiver according to the channel assignment of your radio (see pic #1 below).
4. Connect a flight battery pack to the ESC.
5. Go to the Flap setup menu.
6. In the menu, set the Flap and Flap 2 value to 40% of the total travel as a starting point. Please also check at this time that the servo travel and direction of all the flap servos are operating with the same travel and in the same direction. If not please reverse any servo(s) that are travelling in the wrong direction and adjust the throws.
7. Adjust the servo arm until it reaches an angle of about 20 degree by using the sub trim on the radio. Then install the servo arm and flap control linkage to one side of the outboard flap. The zlink should be installed on the second hole from the servo output shaft. Install the ball link socket to the flap control horn with the supplied screw and nyloc nut. (See pic #2)
8. First adjust the flap in the retracted position. Go into the menu and adjust the value until you see the flap is fully retracted. There might be some buzzing sound coming from the servo, if so adjust the end point until the buzzing stops. Once satisfied with the retracted setup, we move next to the flap deployment.
9. Flip the flap switch to the extended position, go into the menu and adjust the end point value until the flap has travelled about 13 mm (down) which is about level to the inboard flap in the full extended position. Do not allow the outboard flaps to exceed the indicated throw as this might cause difficulties in controlling the plane when the flying speed gets low. When you are satisfied with this setup you may proceed to do the same on the other side.
10. Repeat the above setup from #7 to #9.
11. You may also adjust the ball socket on the linkages to ensure all the flap control surfaces retract and deploy evenly.

12. Finally check again to ensure all the flap control surfaces are operating in the same manner.

13. Pic #3 below shows the inboard and outboard flaps when fully deployed.



Pic #1



Pic #2



Pic #3

Cargo bay door setting procedure:

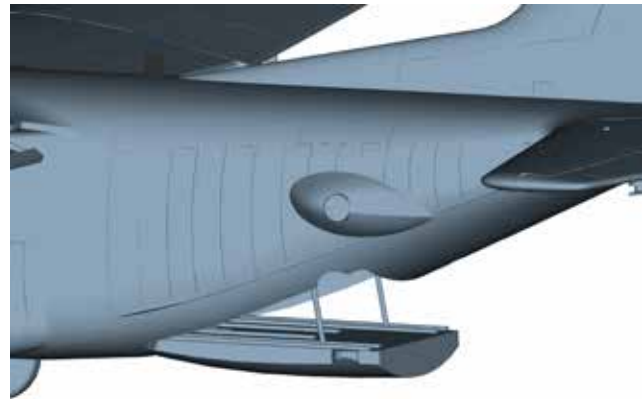
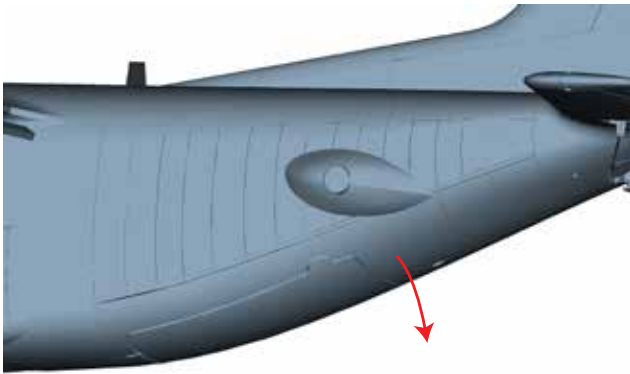

1. Switch on your radio. You can either assign a two way switch or a three way switch to a free channel to operate the cargo bay door.
2. Then go into the end points setup page.
3. Adjust both end points to approximately 30% of the total travel on either side.
4. Plug the cargo bay servo lead (brake) into the selected channel on the receiver.
5. Leave the cargo bay door half open and power up the receiver.
6. The door should not move too much if the end points have been adjusted correctly.

For a two way switch setup

1. Adjust the end point so that with the switch position selecting the door closed and the door is flushed with the fuselage and there is no buzzing from the servo.
2. Flick the switch to the door down position and adjust the end point so that the door just misses the ground.

For a three way switch setup

1. Flick the switch to the door up position and adjust the end point value until it is flushed with the fuselage and there is no buzzing from the servo.
2. Flick the switch to the door halfway open position and adjust the end point value so that the door is levelled to the fuselage main axis.
3. Flick the switch to the door down position and adjust the end point value so that the door just misses the ground.

Note: This setup need to be adjusted carefully since a stalled cargo bay door servo will drain the battery excessively and may even burn the servo motor when the cargo bay door is opened or closed beyond the mechanical end points.

Radio set up for landing gear and door sequencer.

Turn the plane upside down and put the C-130 ideally on a plane stand.

1. The landing gear should be in the fully retracted position. (with wheels retracted and wheel doors closed).
2. Hook up the battery to the power input cables.
3. Cycle the gear switch once.
4. You will see all the gear doors open and you need to wait until all the wheel doors are closed again.
5. Landing gear radio setup has been completed.

To Test.

Cycle the retractable landing gear once to ensure it is operating in the correct sequence.

Flick the retract switch to the wheels down position. It should operate normally with all the wheels in the down position.

Flick the retract switch to the retracted position, it will just retract normally with all the wheels retracting and with all the gear doors closed.

When you need to replace a fresh battery pack after a flight please follow the procedure below.

Put the C-130 on a plane stand.

1. With landing wheels down (gear switch should be in gear down position).
2. Replace the depleted battery with a fresh battery pack and hook it up to the power input cables.
3. Cycle the gear switch once.
4. Only the nose gear door will open and close again (Nose wheels and main wheels will remain in the down position).
5. Flick the retract switch to the retracted position. It will operate normally with all the wheels retracting and all the doors closed.

Note: Whenever the battery pack is unplugged from the power input cable on the C-130 then please cycle the retract switch once to let the system re-learn the program sequence. Cycle the landing gear (extend and retract) once to ensure it operates smoothly without any issues.

Throttle calibration instructions.

When you use the ESC's for the first time, we recommend you calibrate them to your radio system, this will improve the throttle response. Please see below the following steps of how to set it up.

Note: Kindly be reminded that it is safer to ask someone to help and hold the plane for you when performing the ESC throttle calibration.

1. Set the end points of the throttle function on you transmitter to 0% at zero throttle and 100% at full throttle.
2. Power on your transmitter and push your throttle stick to full throttle, 100%.
3. Connect the flight battery to your C130, you will hear tones “W V” from the motors to confirm the end point after approximately 3 seconds.
4. Move the throttle stick back to 0% immediately after you hear the “W V” tones.
5. This completes the throttle calibration procedure.
6. Unplug the flight pack then switch off the transmitter.
7. Before flying ensure the battery is fully re-charged.

Scale detail parts assembly:

Pictures showing the fitting of the windshield wipers.

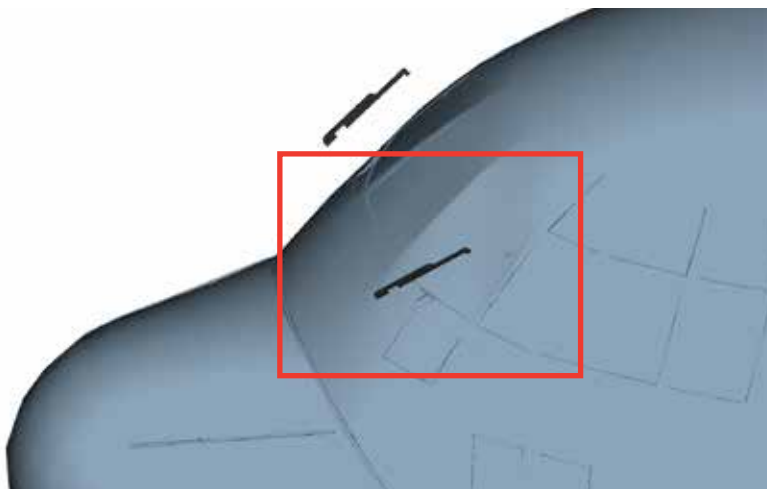

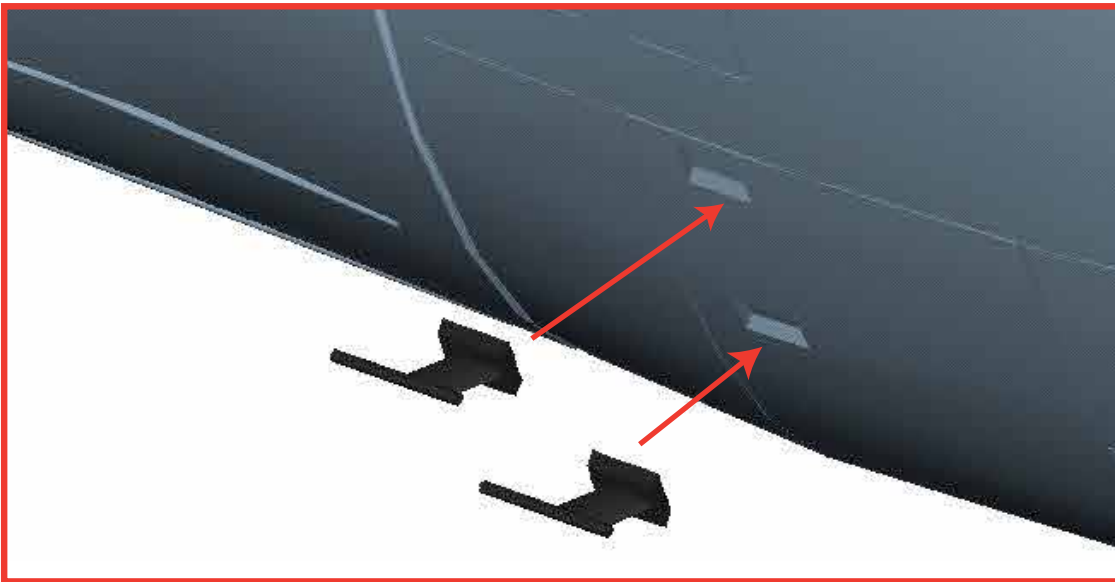

Fitting the pitot tubes.

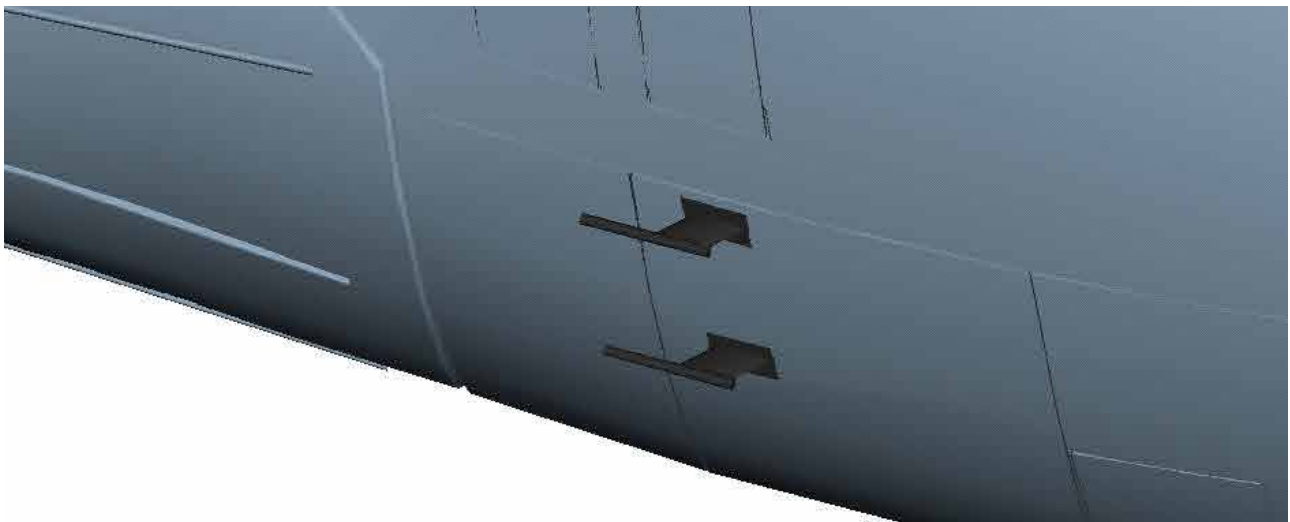

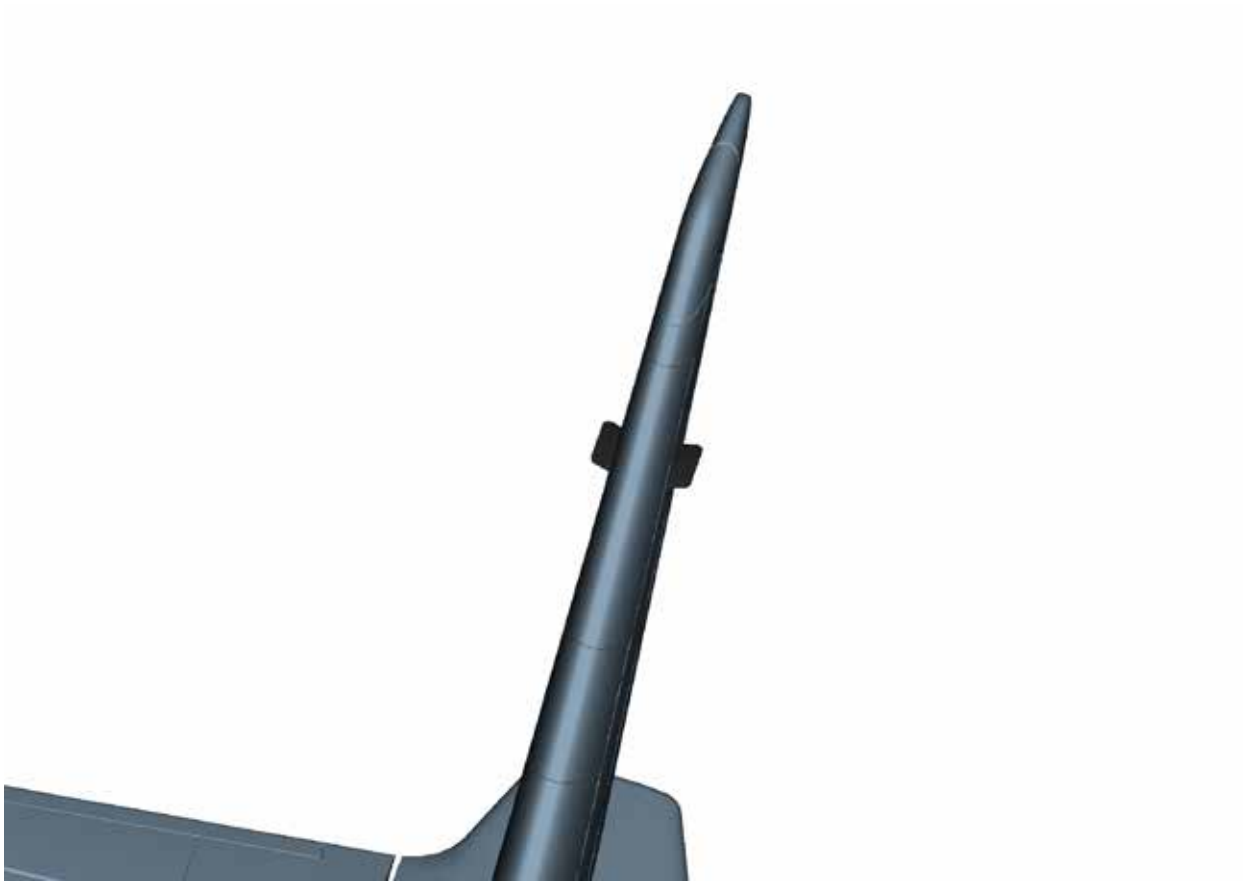
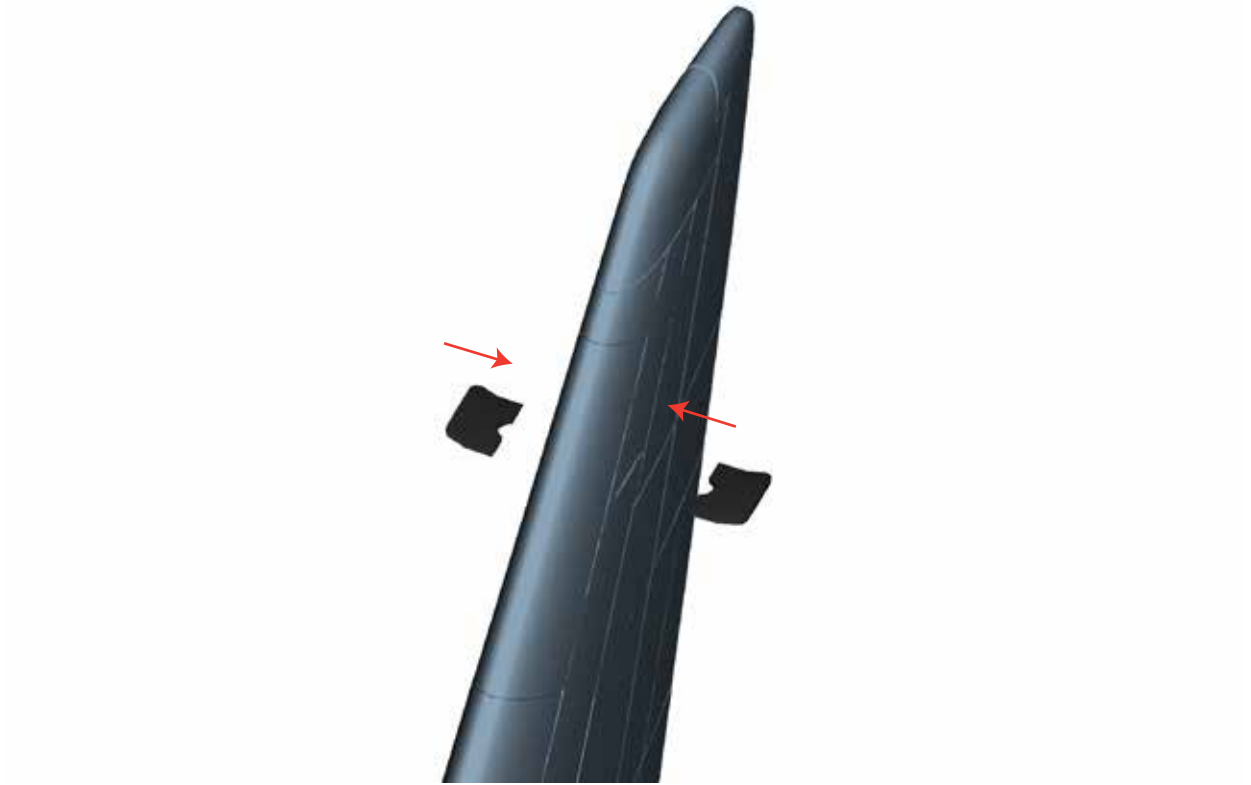

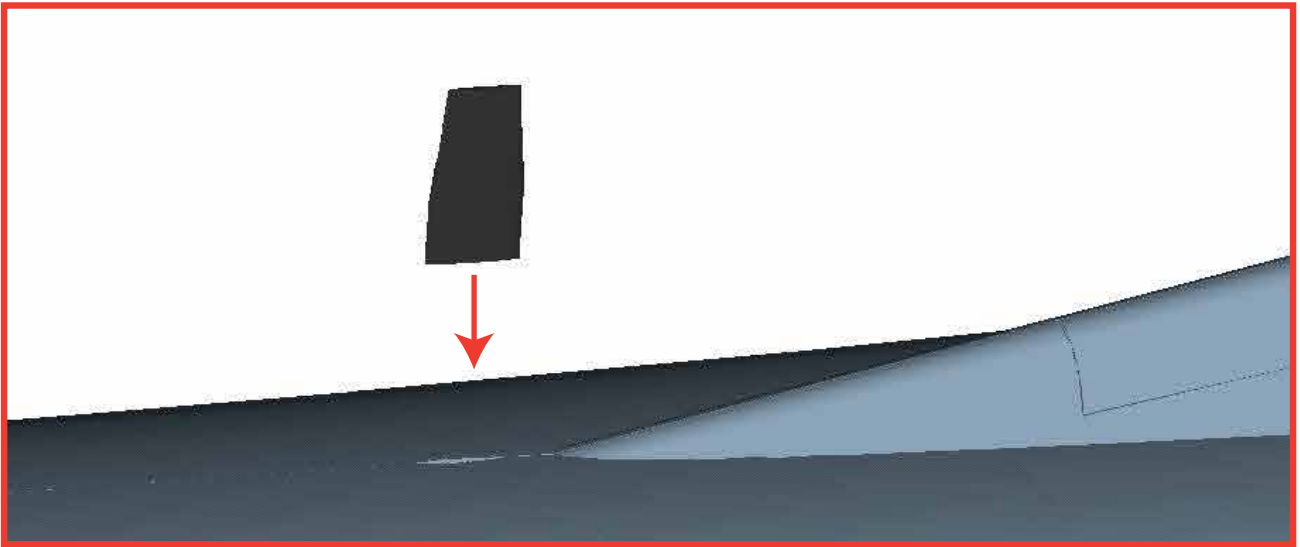

Fitting the dew point sensor.

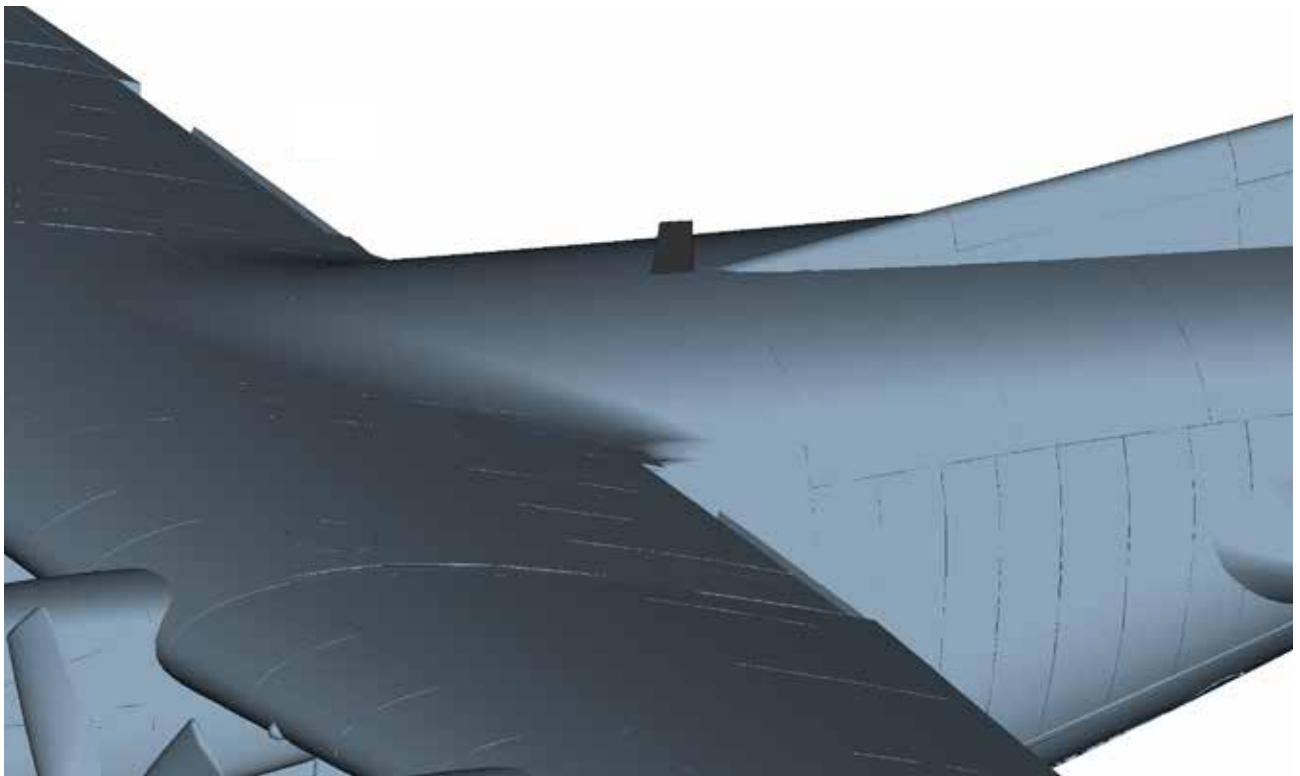

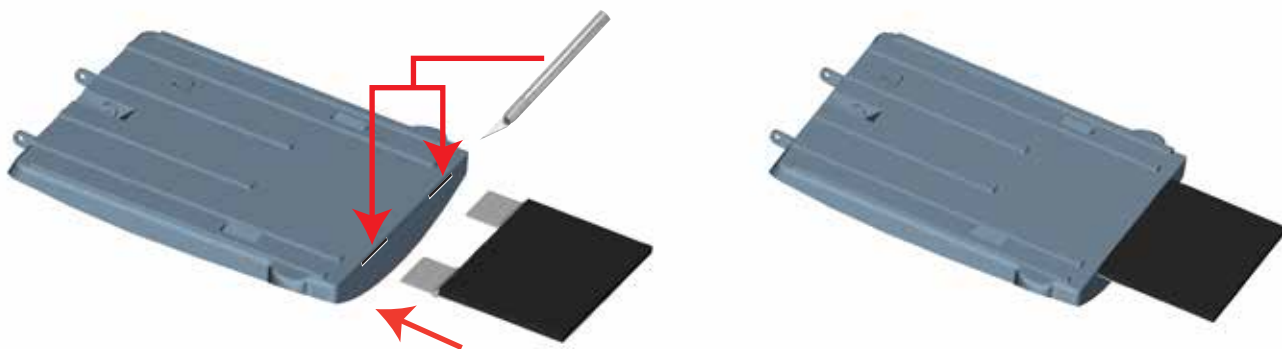

Note: The cargo door ramp is just only for you to install it when you want to display your Avios C-130 on the ground for the most ultimate scale looking model. Please don't install it and use it in flight whatsoever. Again, the ramp is for display purposes only.



Direction of propellers rotation

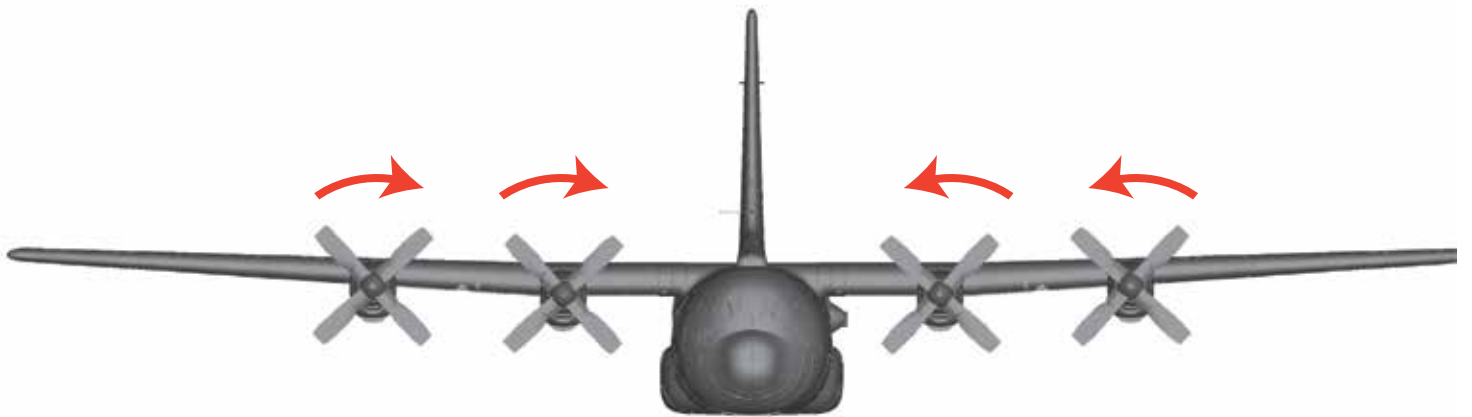

CAUTION: Please stay away the spinning propellers at all times.

Accessories

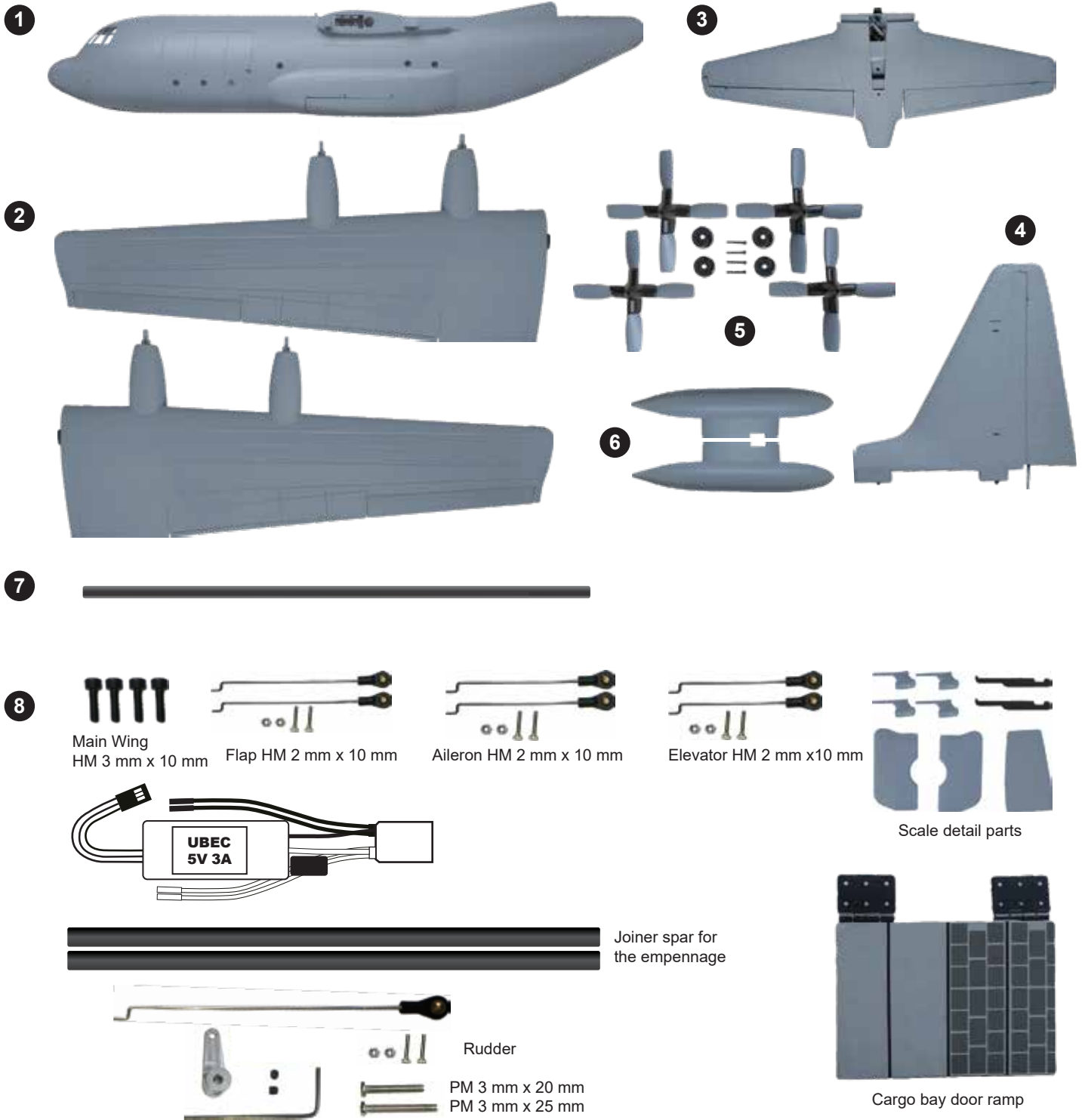

- | | | |
|-------------------|------------------|--|
| 1 Fuselage | 4 Vertical tail | 7 Wing joiner |
| 2 Main wing | 5 Propeller | 8 Control linkages accessory parts, ubec and cargo bay door ramp |
| 3 Horizontal tail | 6 Auxiliary tank | |

■ Recommended Control Throws

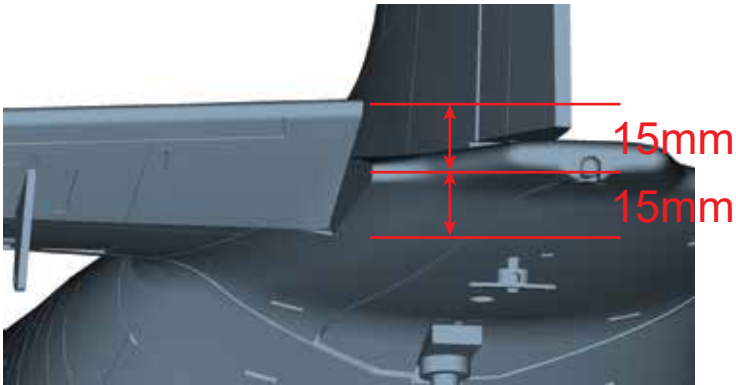

Elevator travel: 15mm up / 15mm down



Ailerons travel: 10-12mm up / 10-12mm down





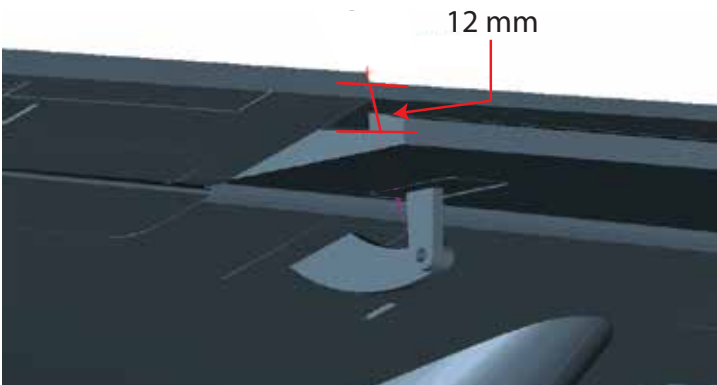





Rudder travel: 10-12mm left / 10-12mm right



Outboard flap travel: 12mm down

■ Specifications

	6.5 x 5 inch 4-blade propeller x 4 pcs
	Brushless Outrunner Motor, 4S 2627 KV1000
	18A Brushless ESC x 4 pcs
	Servos: 9 g x 14 pcs
	Battery: 2200 mAh 4S 14.8V 40C (Recommended)
	Radio System: 2.4 Ghz 8 Ch & up Transmitter and Receiver
	2.4 kg (PNP with flight pack battery)
	With retractable landing gears & lighting system

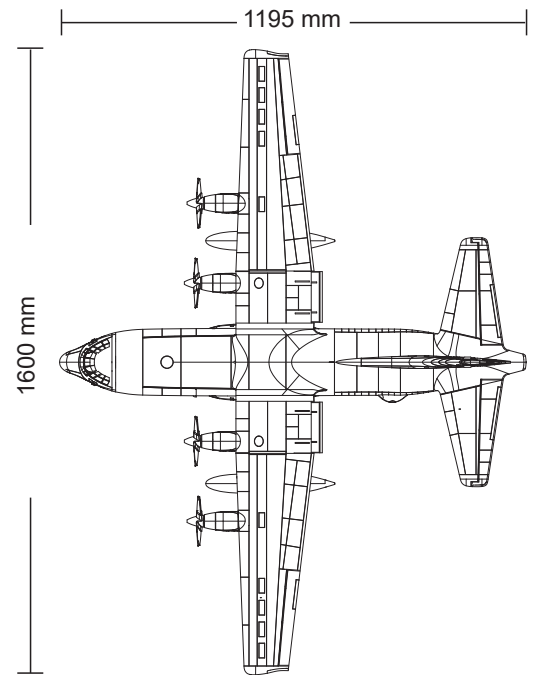

■ CG Location

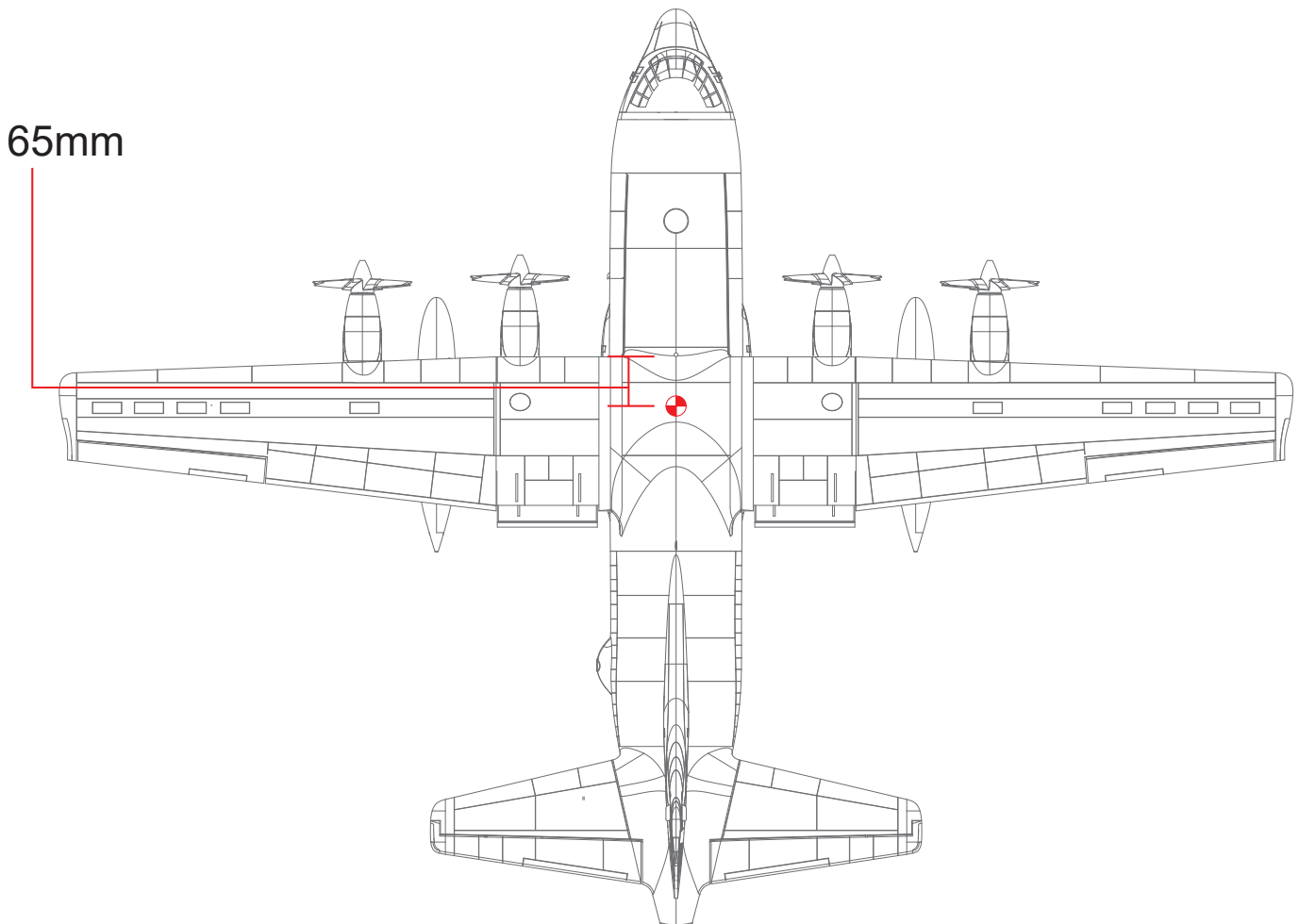

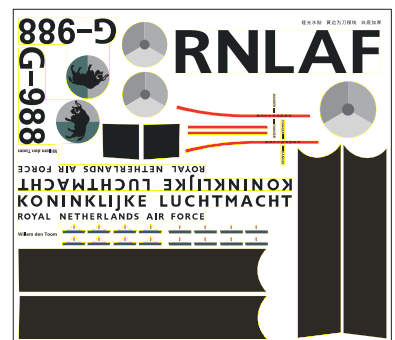
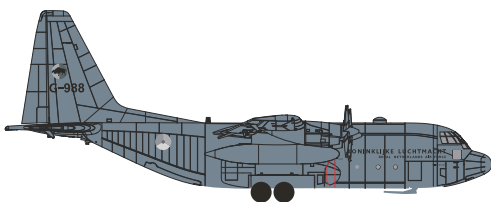
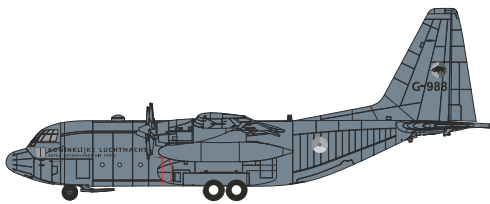
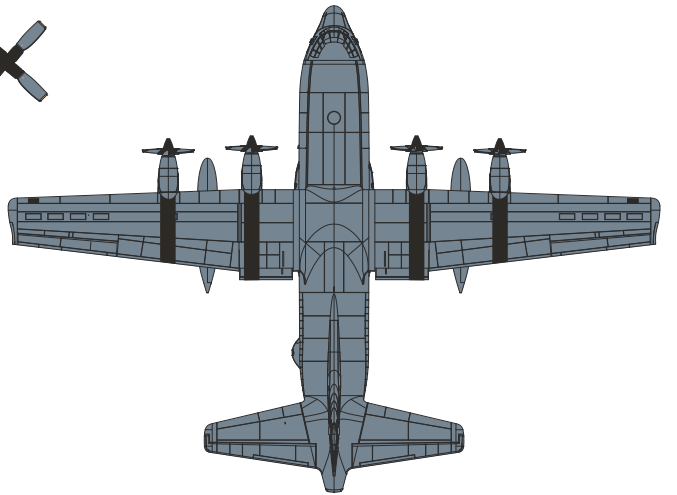
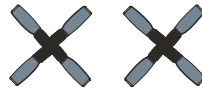
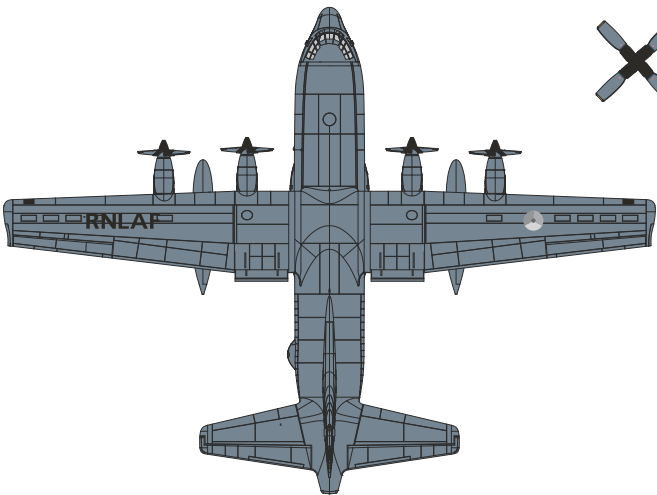
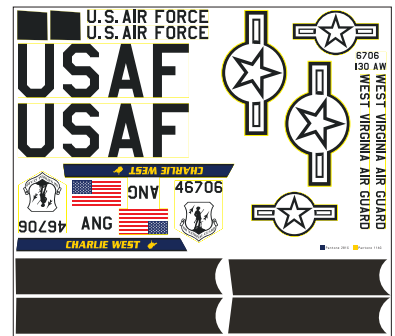
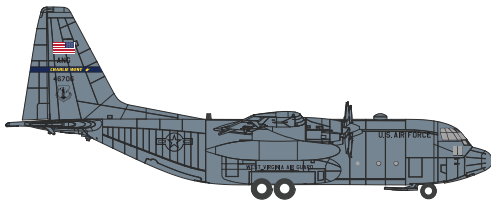
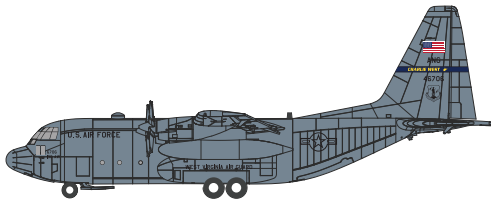
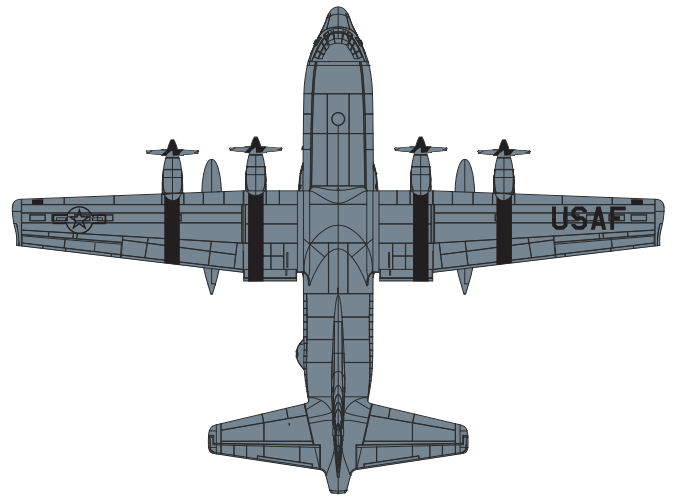
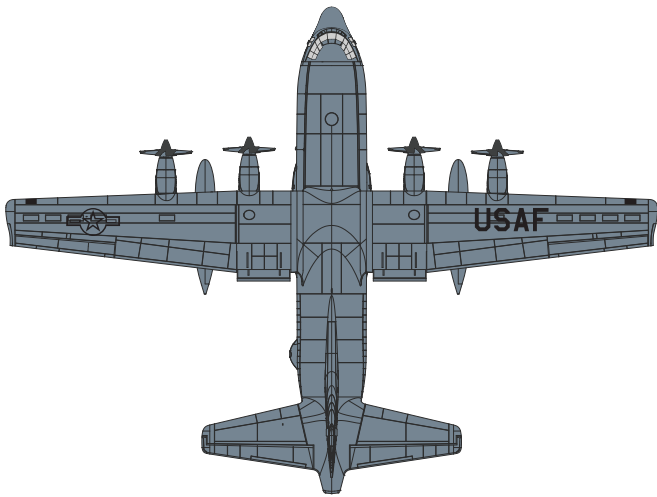

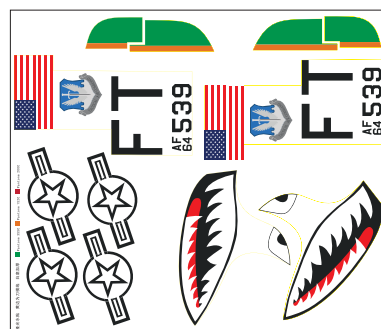
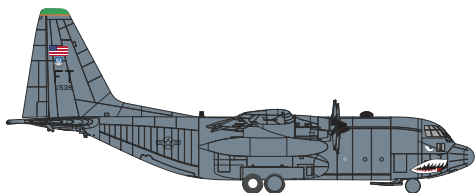
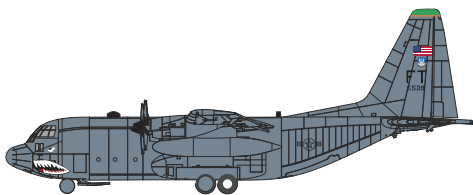
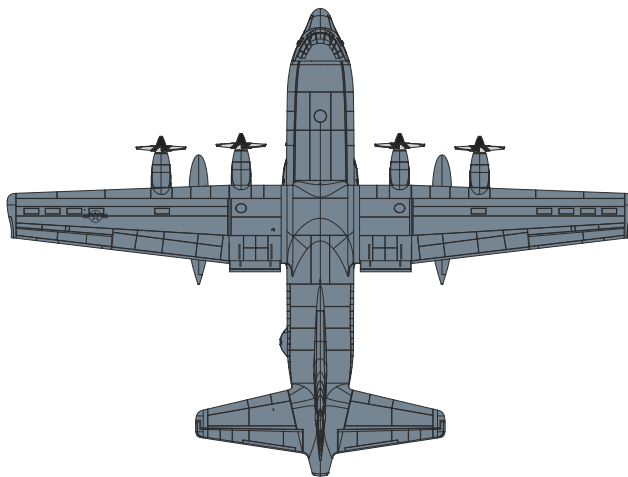
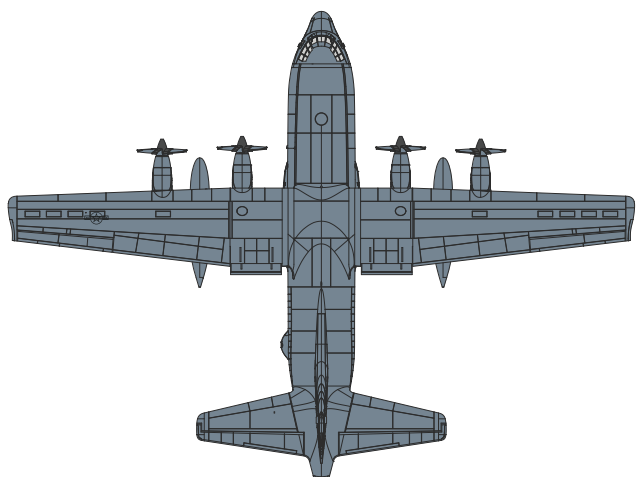
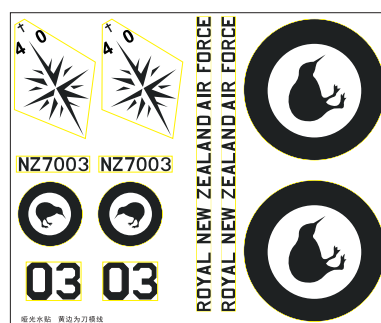
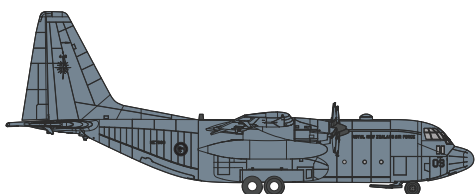
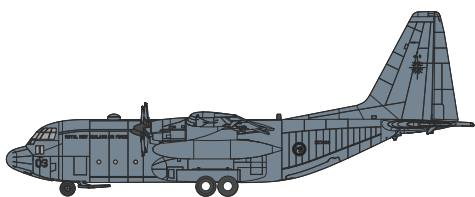
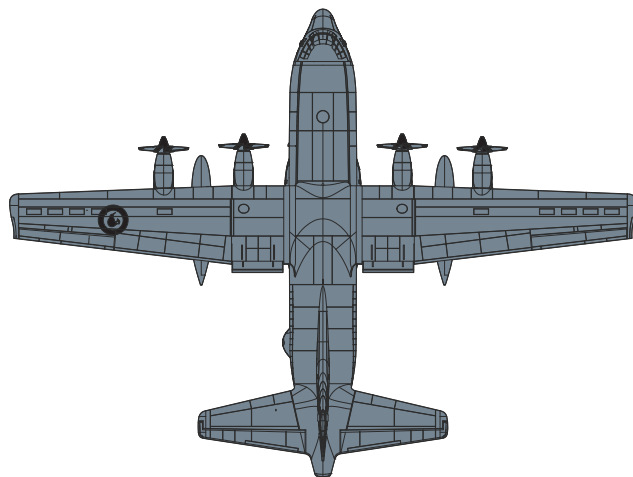
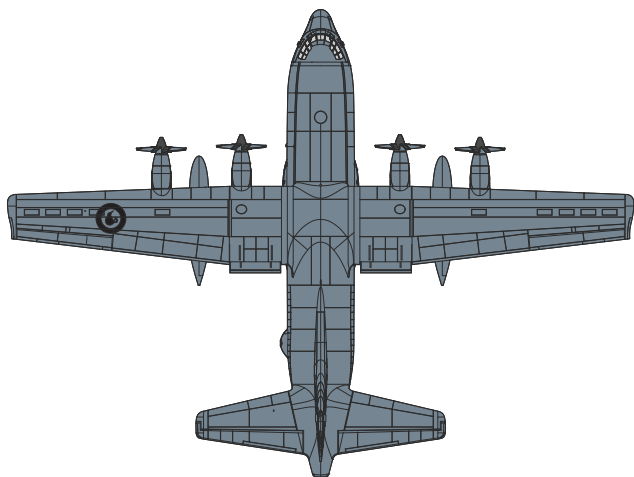



We reserve the right to change or modify the specification and the product design of this product without prior notice.

